



**PROJECT  
SERIES**

# PROJECT SERIES | 600

Designed with your budget in mind.

**1 BOWL**



## PROJECT SERIES 600

The PROJECT SERIES of sinks are well-made and affordable, offering practical kitchen and laundry solutions. They are made from high grade 18/10, 304, stainless steel in 0.8mm gauge. Lifetime limited warranty on stainless steel.

## SPECIFICATIONS

### Dimensions

Overall Size: 580 x 430 x 180mm  
Main Bowl Size: 530 x 380 x 180mm  
Minimum Cabinet: 650mm

### Product Details

Installation: Topmounted  
Material: High grade, 304, 18/10 Stainless Steel  
Thickness: 0.8mm gauge  
Finish: Silk  
Reversible: No  
Edge detail: Laser edge

## PRODUCT FEATURE

### Waste & Overflow System

- Basket waste with overflow kit and clips included
- 90mm waste hole.

### Warranty

Lifetime limited warranty on stainless steel.

### Product Sku Code

Project PR 1B 600

### Note

All dimensions are shown in millimetres and are approximate these should be checked prior to installation. We recommend that all sinks are installed by a professional installer as warranties may be void.



**MM BRANDS**  
263 Ti Rakau Drive, East Tamaki,  
Auckland 2140, New Zealand.

**Help & Support**  
For more information please go  
to our website or contact us.

Call: +64 9 274 0111 or 0800 536 252  
Email: [sales@mmbrands.co.nz](mailto:sales@mmbrands.co.nz)  
[www.sinxbytotara.co.nz](http://www.sinxbytotara.co.nz)

# PROJECT SERIES | 600

CUT-OUTS FOR BOTH TOPMOUNT, UNDERMOUNT & WELDED

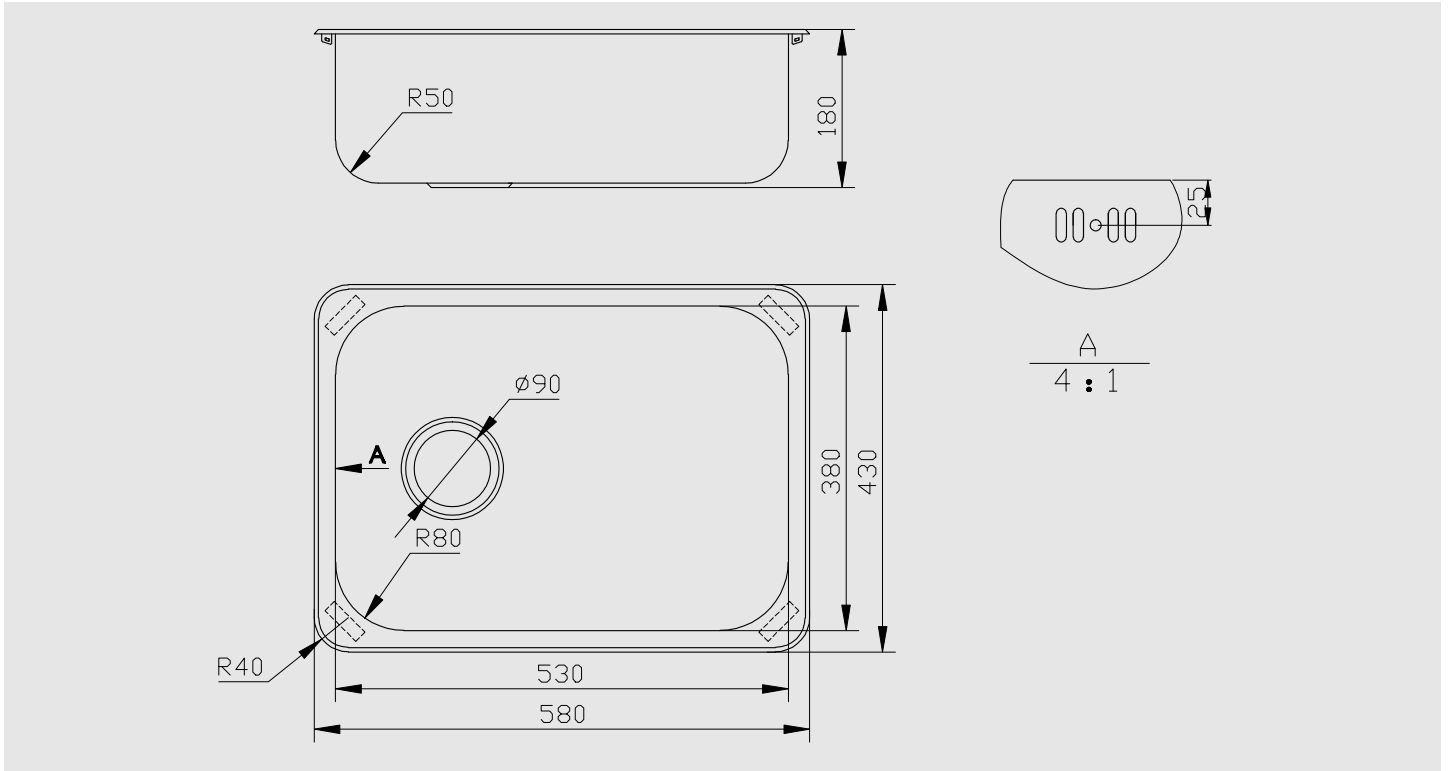

## CUT-OUT FOR TOPMOUNT

